



**Instrumentation
Northwest**

**Manufacturer of Groundwater Monitoring
Systems and Submersible Sensors**

Submersible Pressure Transmitter PS98i

**INSTRUCTION
MANUAL**

Table of Contents

Introduction - PS98i 4-20 mA Transmitter	2
Initial Inspection and Handling	2
Do's and Don'ts	2
General Information	3
Installation	5
Monitoring Wells	5
Other Installations	6
Maintenance	6
Troubleshooting	7
Erratic Readings	7
Oscillating Readings Over Time	7
Zero Readings When Pressurized	8
Technical Specifications	8
Component and Wiring Information	9
Operating Pressure Specifications	10
Mechanical Specifications	10
Adaptors	10
Reordering Information	11
Limited Warranty/Disclaimer - PS98i	12

Information in this document is subject to change without notice and does not represent a commitment on the part of the manufacturer. No part of this manual may be reproduced or transmitted in any form or by any means, electronic or mechanical, including photocopying and recording, for any purpose without the express written permission of the manufacturer.

Introduction - PS98i 4-20 mA Transmitter

The PS98i Pressure Transmitter represents the latest state-of-the-art technology and has been designed to provide trouble-free submersible operation in liquid environments, when properly installed and operated. Please take the time to read through this manual if you are not familiar with this product.

Initial Inspection and Handling

Upon receipt of your transmitter, inspect the shipping package for damage. If any damage is apparent, note the signs of damage on the appropriate shipping form. After opening the carton, look for concealed damage such as a cut cable. If concealed damage is found, immediately file a claim with the carrier.

Check the etched label on the transmitter to be sure that the proper range and type were provided. Also check the label attached to the cable at the connector end for the proper cable length.

Do's and Don'ts

Do handle the device with care.

Do store the device in a dry, inside area when not in use.

Do install a desiccant tube if you are doing long-term outdoor monitoring.

Don't install the device so that the connector end is submerged.

Don't support the device with the connector or with the connectors of an extension cable. Use a strain relief device to take the tension off the connectors.

Don't allow the device to free-fall down a well at high velocities as impact damage can occur.

Don't bang or drop the device on hard objects.

Don't disassemble the device. (The warranty is void if transmitter is disassembled.)

General Information

The following paragraphs outline the basics of how pressure is measured using submersible pressure transmitters:

Liquids and gasses do not retain a fixed shape. Both have the ability to flow and are often referred to as fluids. One fundamental law for a fluid is that the fluid exerts an equal pressure in all directions at a given level. Further, this pressure increases with an increasing depth of “submergence”. If the density of a fluid remains constant (noncompressible...a generally good assumption for water at “normal” pressures and temperatures), this pressure increases linearly with the depth of “submergence”.

We are all “submerged” in the atmosphere. As we increase our elevation, the pressure exerted on our bodies decreases as there is less of this fluid above us. It should be noted that atmospheric pressure at a given level does vary with changes in the weather. One standard atmosphere (pressure at sea level on a “normal” day) is defined to be 14.7 PSI (pounds per square inch).

There are several methods to reference a pressure measurement (see Figure 1). Absolute pressure is measured with respect to an ideal vacuum (no pressure). Gauge pressure is the most common way we express pressure in every day life and is the pressure exerted over and above atmospheric pressure. With this in mind, gauge pressure (P_g) can be expressed as the difference between the absolute pressure (P_a) and atmospheric pressure (P_{atm}):

$$P_g = P_a - P_{atm}$$

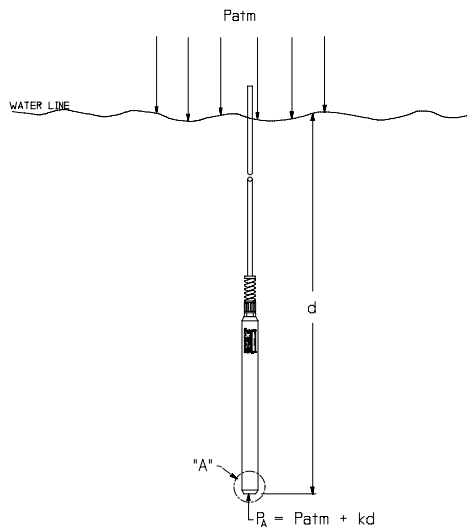

Figure 1. Pressure Diagram

To measure gauge pressure, atmospheric pressure is subjected to one side of the system and the pressure to be measured is subjected to the other. The result is that the differential (gauge pressure) is measured. A tire pressure gauge is a common example of this type of device.

Recall that as the level of submergence increases (in an incompressible fluid), the pressure increases linearly. Also, recall that changes in weather cause the absolute atmospheric pressure to change. In water, the absolute pressure P_a at some level of depth (d) is given as follows (see Figure 2):

$$P_a = P_{atm} + kd$$

where k is simply a constant (i.e.: 2.307 ft of water = 1 PSI)

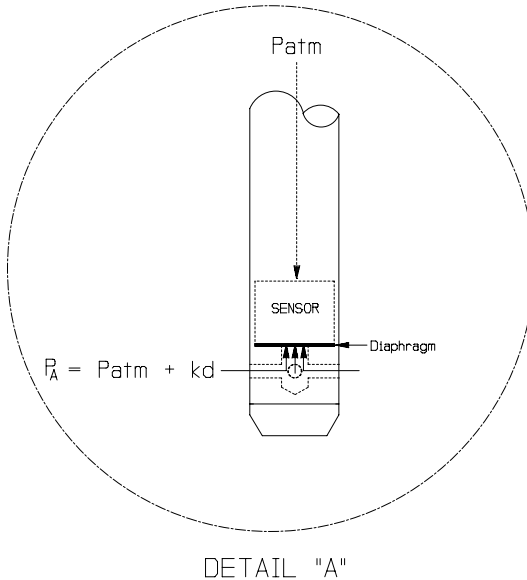

Figure 2. Pressure Diagram, Detail "A"

INW's standard gauge submersible pressure devices utilize a vent tube in the cable to allow the device to reference atmospheric pressure. The resulting gauge pressure measurement reflects only the depth of submergence. That is, the net pressure on the diaphragm (Figure 2) is due entirely to the depth of submergence.

Installation

The PS98i measures pressure. The most common application is measuring liquid levels in wells and tanks. In order to do this, the transmitter must be installed below the water level at a fixed depth. The installation depth depends on the range of the transmitter. One (1) PSI is equal to approximately 2.31 feet of water. If you have a 5 PSI transmitter, the range is 11.55 feet of water and the transmitter should not be installed at a depth below 11.55 feet. If the transmitter is installed below its maximum range, damage may result to the transmitter and the output reading will not be correct.

Monitoring Wells

Lower the transmitter to the desired depth. Fasten the cable to the well head using tie wraps or a weather proof strain-relief system. When securing the cable, make sure not to pinch the cable too tightly or the vent tube inside the cable jacket may be sealed off. Take a measurement to insure the transmitter is not installed below its maximum range. It is recommended that several readings be taken to insure proper operation after installation.

Important Note: If the transmitter is to be left in the well for a long-term monitoring application and the connector end is not in a dry, thermally-stable environment, a desiccant tube must be installed in line with the cable to prevent condensation in the cable vent tube. Water in the vent tube will cause inaccurate readings and, in time, will work its way into the transmitter and damage it.

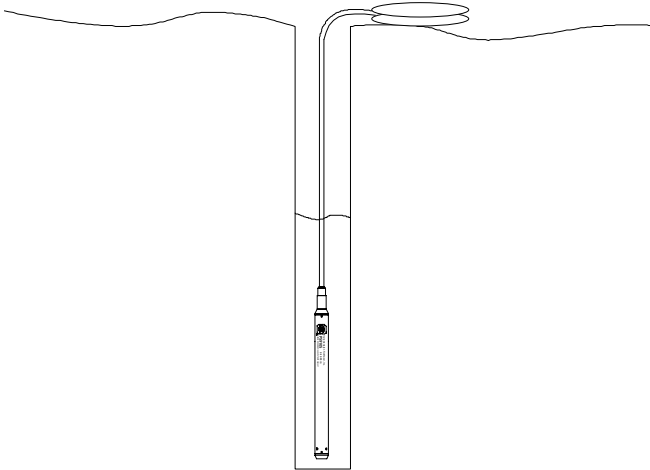

Figure 3: Installation

Other Installations

The transmitter can be installed in any position; however, when it leaves the factory it is tested in the vertical position. Strapping the transmitter body with tie wraps or tape will not hurt it. If the transmitter is being installed in a fluid environment other than water, be sure to check the compatibility of the fluid with the wetted parts of the transmitter. INW can provide a variety of seal materials if you are planning to install the transmitter in an environment other than water.

Maintenance

INW recommends that the transmitter be returned for factory recalibration and check-up every six months or if problems develop with sensor stability or accuracy. If the transmitters have been exposed to hazardous materials, do not return them without notification and authorization. INW will ask that if the transmitter assembly has been exposed to hazardous or toxic chemicals, you send back only the transmitter and end connector, discarding the cable.

Transmitter - all models: There are no user-serviceable parts.

Cable: Cable can be damaged by abrasion, sharp objects, twisting, crimping or crushing and pulling. Take care during installation and use to avoid cable damage. If a section of cable is damaged, it is recommended that you send your sensor back to replace the cable harness assembly.

End Connections: The contact areas (pins & sockets) of Mil-spec connectors will wear out with extensive use. If your application requires repeated connections (in excess of 5000 connections) other types of connectors can be provided. The connectors used by INW not submersible, but are designed to be splash-resistant.

Desiccant Tubes: Inspect the Desiccant Tube at least once every two months. The desiccant is a bright blue color when active and dry, as moisture is absorbed the color will begin to fade until becoming white indicating full saturation and time to replace. Replacement desiccant can be purchased from INW, please contact an INW sales engineer at 1-800-776-9355 for more information.

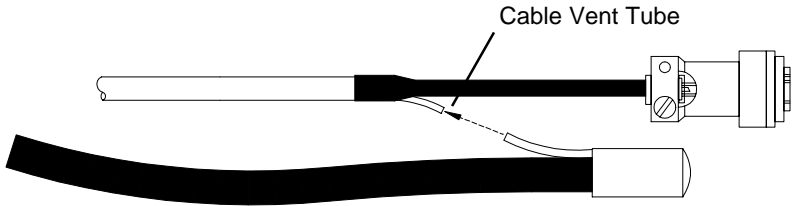

Figure 4. Desiccant Tube

Troubleshooting

Erratic Readings

Erratic readings can be caused by a damaged transmitter, damaged cable, poor connections or improper operation of readout equipment. In most cases, erratic readings are due to moisture getting into the system. Assuming that the readout equipment is working correctly, the first thing to check is the connection. Look for moisture between contacts or a loose or broken wire. If the connection appears OK, pull the transmitter up a known distance while monitoring its output. If the transmitter responds approximately as it should, but the reading is still erratic, most likely the cable is damaged. If the transmitter does not respond approximately as it should, it is most likely that the sensor is damaged. In either case, consult the factory.

Oscillating Readings Over Time

If, after time, your transmitter is functioning normally but your data is showing a cyclic effect in the absence of water level changes, you are probably seeing barometric changes. The amount is usually .5 to 1.5 feet of water. This can be caused by a plugged vent tube in the cable or actual water level changes in the aquifer itself in response to barometric pressure changes. This effect can occur in tight formations where the transmitter will immediately pick up barometric changes but the aquifer will not. If you think you are having this type of problem you will have to record the barometric pressure as well as the water level pressure and compensate the data. If it appears that the vent tube is plugged, consult the factory.

If a desiccant tube is not installed in line with the cable, water may have condensed in your vent tube causing it to plug. After you are finished installing the desiccant tube you can test the vent tube by applying a small amount of pressure to the end of the desiccant tube and seeing if this affects the transmitter reading.

Zero Readings When Pressurized

Continuous zero readings are caused by an open circuit which usually indicates broken cable, a bad connection, or possibly a damaged transmitter. Check the connector to see if a wire has become loose, or if the cable has been cut. If neither of these appears to cause the problem, the transmitter needs factory repair.

Technical Specifications

The PS98i submersible pressure transmitter represents the latest in state-of-the-art level measurement technology. This industry standard two-wire, 4-20 mA device offers improved noise immunity, thermal performance and transient protection. In addition to reverse polarity protection, under-current and over-current limitation are featured on both transmitter channels.

As mentioned above, the PS98i transmitter is a current loop device. This means that changes in pressure imposed on the stainless steel diaphragm result in proportional changes in current. The excitation source (DC supply or data logger) supplies the power but the transmitter actually controls how much current flows as long as the excitation specifications (e.g., voltage level) are met.

For a standard gauge pressure device, there is zero pressure on the diaphragm when above the surface of the liquid. This zero pressure is converted to a current flow of 4 mA. As the transmitter is lowered into the liquid, the amount of current that flows increases linearly (with increasing depth) to 20 mA when the maximum rated pressure (thus depth) is reached. That is, there is a straight line relationship between pressure (thus depth of submergence) and the amount of current that flows. A data logger therefore can apply power, measure the amount of current that is flowing and convert that to the depth of submergence using a multiplier and offset (m and b, respectively, for a $y = mx + b$ straight line) which are preset in the logger by the user.

There are a number of differences in regards to data loggers. However, in most data loggers, the current that flows is converted to a voltage that is measured. The multiplier and offset operate on this measured voltage to provide desired units. For INW's Aquistar data loggers DL-1, DL-1A, DL-2 and DL-4A through DL-16A, the multiplier and offset can be calculated as follows:

$$M = P_{max}/4$$
$$b = -P_{max}/4,$$

where P_{max} is the rated range of the transmitter. This can be in PSI or in feet of water (1 PSI is approximately equal to 2.31 feet of water).

Component and Wiring Information

The following is a diagram of the transmitter components. The list below specifies wiring information for the PS98i.

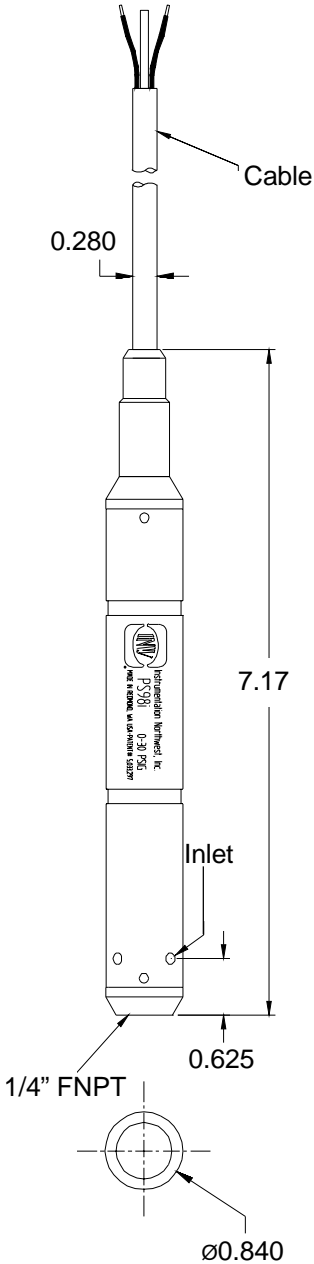

PS98i Wiring Information:

Cable Type: 9-conductor, vented

Shield = ground

White = (V+) pressure

Blue = pressure signal return

Figure 5. Transmitter Components

Operating Pressure Specifications

Static Accuracy	±0.25% FSO (max.) <i>0.1% available on request.</i>	±0.1% FSO (typ.) B.F.S.L. 25° C
Thermal Error (0-50° C, reference 25° C)	±2.0% FSO (max.)	±0.8% FSO (typ.)
Max. Zero Offset at 25° C	±0.5% FSO	
Max. Temperature Error	±2.0% FSO	
Over Range Protection	2x (except 300 PSIA)	
Operating Temp. Range	-5° C to 70° C	

Mechanical Specifications

Transmitter --	
Length:	7.17"
O.D.:	0.840"
Body Material:	316 stainless steel
Wire Seal Material:	Viton & Teflon
Diaphragm:	316 stainless steel
Desiccant Tube:	High & standard capacity available
Terminating Connector:	Available
Cable --	
O.D.:	max. 0.28"
Cable Jacket:	Polyurethane
Conductor Type:	9-conductor, vented
Vent Tube:	Nylon
Break Strength:	138 lbs.
Maximum Length:	2000 ft.

Adaptors

The following adaptors are available. Contact your INW representative for details and ordering information.

- 1/4" male NPT pipe fitting
- 1" male pipe adaptor
- 1" conduit adaptor

Reordering Information

For sales & service offices, please contact:

Instrumentation Northwest, Inc.

www.inwusa.com

800-776-9355

LIMITED WARRANTY/DISCLAIMER - PS98i

A. Seller warrants that products manufactured by Seller when properly installed, used and maintained **with a properly installed desiccant tube**, shall be free from defects in material and workmanship. Seller's obligation under this warranty shall be limited to replacing or repairing the part or parts or, at Seller's option, the products which prove defective in material or workmanship within ONE (1) year from the date of delivery, provided that Buyer gives Seller prompt notice of any defect or failure and satisfactory proof thereof. Any defective part or parts must be returned to Seller's factory or to an authorized service center for inspection. Buyer will prepay all freight charges to return any products to Seller's factory, or any other repair facility designated by Seller. Seller will deliver replacements for defective products to Buyer (ground freight prepaid) to the destination provided in the original order. Products returned to Seller for which Seller provides replacement under this warranty shall become the property of Seller.

This limited warranty does not apply to lack of performance caused by abrasive materials, corrosion due to aggressive fluids, mishandling or misapplication. Seller's obligations under this warranty shall not apply to any product which (a) is normally consumed in operation, or (b) has a normal life inherently shorter than the warranty period stated herein.

In the event that equipment is altered or repaired by the Buyer without prior written approval by the Seller, all warranties are void. Equipment and accessories not manufactured by the Seller are warranted only to the extent of and by the original manufacturer's warranty.

THE FOREGOING WARRANTIES ARE IN LIEU OF ALL OTHER WARRANTIES, WHETHER ORAL, WRITTEN, EXPRESSED, IMPLIED OR STATUTORY. IMPLIED WARRANTIES OF FITNESS AND MERCHANTABILITY SHALL NOT APPLY. SELLER'S WARRANTY OBLIGATIONS AND BUYER'S REMEDIES THEREUNDER (EXCEPT AS TO TITLE) ARE SOLELY AND EXCLUSIVELY AS STATED HEREIN. IN NO CASE WILL SELLER BE LIABLE FOR CONSEQUENTIAL DAMAGES, LABOR PERFORMED IN CONNECTION WITH REMOVAL AND REPLACEMENT OF THE SENSOR SYSTEM, LOSS OF PRODUCTION OR ANY OTHER LOSS INCURRED BECAUSE OF INTERRUPTION OF SERVICE. A NEW WARRANTY PERIOD SHALL NOT BE ESTABLISHED FOR REPAIRED OR REPLACED MATERIAL, PRODUCTS OR SUPPLIES. SUCH ITEMS SHALL REMAIN UNDER WARRANTY ONLY FOR THE REMAINDER OF THE WARRANTY PERIOD ON THE ORIGINAL MATERIALS, PRODUCTS OR SUPPLIES.

B. With respect to products purchased by consumers in the United States for personal use, the implied warranties including but not limited to the warranties of merchantability and fitness for a particular purpose, are limited to twelve (12) months from the date of delivery.

Some states do not allow limitations on the duration of an implied warranty, so the above limitation may not apply to you. Similarly, some states do not allow the exclusion or limitation of consequential damages, so the above limitation or exclusion may not apply to you. This limited warranty gives you specific legal rights; however, you may also have other rights which may vary from state to state.



www.inwusa.com

Please visit INW's Web site to learn more about our products and services.

Copyright" 1997 - 2002 by Instrumentation Northwest, Inc. All rights reserved.
Instrumentation Northwest and INW are trademarks registered with the
U.S. Patent & Trademark Office.

Printed on recycled paper.

Doc# 9B0005r1 02/2002

P/N 3A341



Instrumentation Northwest, Inc.

8902 122nd Avenue NE

Kirkland, WA 98033

(425) 822-4434  **(425) 822-8384 (fax)**

(800) 776-9355  **www.inwusa.com**